



LEVEL



FLOW



PRESSURE



TEMPERATURE



ELECTRONICS



Датчики уровня серии LINEAR – LCM-O

Архангельск (8182)63-90-72
Астрахань (8512)99-46-04
Барнаул (3852)73-04-60
Белгород (4722)40-23-64
Брянск (4832)59-03-52
Владивосток (423)249-28-31
Волгоград (844)278-03-48
Вологда (8172)26-41-59
Воронеж (473)204-51-73
Екатеринбург (343)384-55-89
Иваново (4932)77-34-06

Ижевск (3412)26-03-58
Иркутск (395)279-98-46
Казань (843)206-01-48
Калининград (4012)72-03-81
Калуга (4842)92-23-67
Кемерово (3842)65-04-62
Киров (8332)68-02-04
Краснодар (861)203-40-90
Красноярск (391)204-63-61
Курск (4712)77-13-04
Липецк (4742)52-20-81

Киргизия (996)312-96-26-47

Магнитогорск (3519)55-03-13
Москва (495)268-04-70
Мурманск (8152)59-64-93
Набережные Челны (8552)20-53-41
Нижний Новгород (831)429-08-12
Новокузнецк (3843)20-46-81
Новосибирск (383)227-86-73
Омск (3812)21-46-40
Орел (4862)44-53-42
Оренбург (3532)37-68-04
Пенза (8412)22-31-16

Казахстан (7273)495-231

Пермь (342)205-81-47
Ростов-на-Дону (863)308-18-15
Рязань (4912)46-61-64
Самара (846)206-03-16
Санкт-Петербург (812)309-46-40
Саратов (845)249-38-78
Севастополь (8692)22-31-93
Симферополь (3652)67-13-56
Смоленск (4812)29-41-54
Сочи (862)225-72-31
Ставрополь (8652)20-65-13

Таджикистан (992)427-82-92-69

Сургут (3462)77-98-35
Тверь (4822)63-31-35
Томск (3822)98-41-53
Тула (4872)74-02-29
Тюмень (3452)66-21-18
Ульяновск (8422)24-23-59
Уфа (347)229-48-12
Хабаровск (4212)92-98-04
Челябинск (351)202-03-61
Череповец (8202)49-02-64
Ярославль (4852)69-52-93

Единый адрес для всех регионов: vck@nt-rt.ru || <https://valco.nt-rt.ru/>

GENERAL FEATURES

Magnetostrictive continuous level transmitters base their operation on the physical principle called Wiedemann effect and it allows continuous and precise measurement of liquid levels. The electronic unit sends a pulse within a waveguide contained in the measuring rod; the magnetic float intercepts the pulse generating an echo that is detected by the same electronic unit.

The elapsing time between the emission of the pulse and its recognition is directly proportional to the position of the float, and then to the value of the level to be measured.

Brass - Spansil

- 1 analog output, current or voltage.
- 2 analog outputs, current and voltage.
- 2 factory programmable PNP digital outputs.
- RS485 serial output, Valco protocol.
- Programming via dedicated handheld computer VSP.130, on request
- Up to 2, 9 m length.
- Working pressure up to 20 bar
- Operating ambient temperature -30 / +70 °C, RH 90%.
- Standard working temperature up to 105 °C
120 °C working temperature on request.
- Minimum degree of protection IP67.



See MULTISIGNAL

TECHNICAL DATA

Tab.1

Power supply	18 ÷ 30 Vcc	Analog output	Current	• 4-20mA	420
Power consumption	< 100 mA		Voltage	0-5V	005
Signal output resolution	< 1 mm			0-10V	010
Accuracy	≤ 1 mm			0,5-4,5V	545
Room temperature	-30 / +70°C	Communication output	Current / Voltage	4-20mA/0-10V	420/10
Process temperature	105° C 150° C with heat sink		RS485 - Valco protocol		RS485
Measuring length L0	2, 9 m - max. 2, 8 m - max. - 150°C application	N.2 Digital output factory programmable	2 x PNP - not protected maximum load 100mA		2PNP
Electrical connection	S5 Conec M12 x 1, 8 poles	Programming of instrument	Via dedicated handheld computer VSP.130 available on request		
Protection class	IP67				

- Standard, others signal output and indicated option on request

FLOATS

Tab.2



B45
Ø30x45

B44
Ø44x50

Material	Spansil – Butadiene - Acrylonitrile Copolymer	
Specific gravity	0,35	0,45
Max. pressure – Bar	20	20
Max. temperature – Class	L = 105°C	M = 120°C

ELECTRICAL OUTPUT

Tab.3

S5	L	105°C	Standard	Anodized aluminum
	M	120°C	With heat sink	

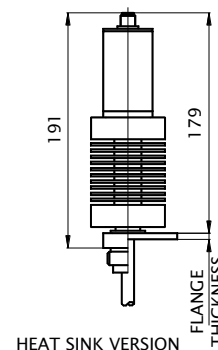
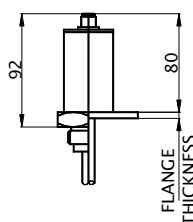

PROCESS CONNECTIONS

Tab.4

Type of float	Mounting from outside					
	25	32	40	50	FOHX	DN65
	1"	1-1/4"	1-1/2"	2"	Flange	Flange
B45	G	G-C-N	G-C-N	-	•	-
B44	-	-	G	G-C-N	-	•

Male thread

G	C	N
Parallel UNI 228/1	Conical UNI 7/1	Conical NPT

Available materials

O	S
brass	AISI-316 on request

DN = Available materials

S	C
AISI-316	Steel on request

FLANGES Dimensions in mm.

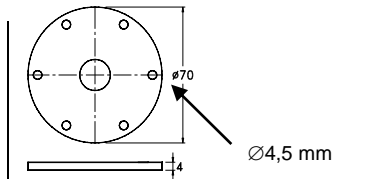

FOHX

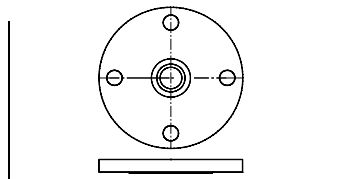

DN = UNI - DIN - ANSI Flanges

A Flanged connection
A1 Threaded

WIRING

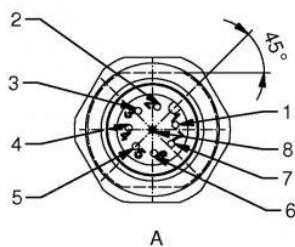

PIN	SIGNAL
1	RS485 - line B
2	Power supply +V
3	RS485 - line A
4	Ground
5	Analog output - voltage
6	Analog output - current
7	Digital output - PNP2
8	Digital output - PNP1

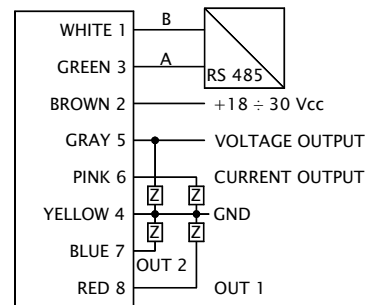

DIMENSIONS mm.

Tab.5

The dimension L0 - LM is measured from the stop of the fitting (A1) or flange (A) connection. Tolerance on dimension L0 - LM ± 3 mm.

	B44	B45
A	75	75
A1	60	60
B	65	85

Damping tube	- L	- O
On request	aluminum	brass

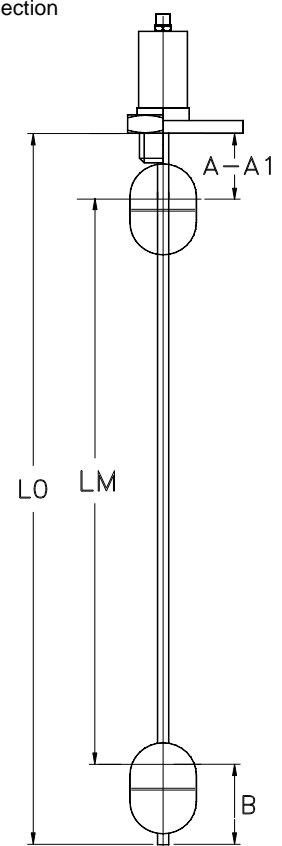

NOMENCLATURE

LCM B44 1300 / 1400 O - L 50 G O 420 S5 L

•											Type
	•										Tab.2 Float
		•									Tab.5 Measuring length LM / Total length L0 (mm)
			•								Tab.2-4 Rod material
				•							Tab.5 Damping tube (option)
					•						Tab.4 Process connection dimension
						•					Tab.4 Process connection thread
							•				Tab.4 Process connection material
								•			Tab.1 Analog output and options required
									•		Tab.3 Electrical output.
										•	Tab.2-3 Temperature class

CABLE- PLUG

Connection cable 2m. with connector M12x1

Accessory on request

По вопросам продажи и поддержки обращайтесь:

Архангельск (8182)63-90-72
Астрахань (8512)99-46-04
Барнаул (3852)73-04-60
Белгород (4722)40-23-64
Брянск (4832)59-03-52
Владивосток (423)249-28-31
Волгоград (844)278-03-48
Волгода (8172)26-41-59
Воронеж (473)204-51-73
Екатеринбург (343)384-55-89
Иваново (4932)77-34-06

Ижевск (3412)26-03-58
Иркутск (395)279-98-46
Казань (843)206-01-48
Калининград (4012)72-03-81
Калуга (4842)92-23-67
Кемерово (3842)65-04-62
Киров (8332)68-02-04
Краснодар (861)203-40-90
Красноярск (391)204-63-61
Курск (4712)77-13-04
Липецк (4742)52-20-81

Киргизия (996)312-96-26-47

Магнитогорск (3519)55-03-13
Москва (495)268-04-70
Мурманск (8152)59-64-93
Набережные Челны (8552)20-53-41
Нижний Новгород (831)429-08-12
Новокузнецк (3843)20-46-81
Новосибирск (383)227-86-73
Омск (3812)21-46-40
Орел (4862)44-53-42
Оренбург (3532)37-68-04
Пенза (8412)22-31-16

Казахстан (7273)495-231

Пермь (342)205-81-47
Ростов-на-Дону (863)308-18-15
Рязань (4912)46-61-64
Самара (846)206-03-16
Санкт-Петербург (812)309-46-40
Саратов (845)249-38-78
Севастополь (8692)22-31-93
Симферополь (3652)67-13-56
Смоленск (4812)29-41-54
Сочи (862)225-72-31
Ставрополь (8652)20-65-13

Таджикистан (992)427-82-92-69

Сургут (3462)77-98-35
Тверь (4822)63-31-35
Томск (3822)98-41-53
Тула (4872)74-02-29
Тюмень (3452)66-21-18
Ульяновск (8422)24-23-59
Уфа (347)229-48-12
Хабаровск (4212)92-98-04
Челябинск (351)202-03-61
Череповец (8202)49-02-64
Ярославль (4852)69-52-93

Единый адрес для всех регионов: vck@nt-rt.ru || <https://valco.nt-rt.ru/>



LEVEL



FLOW



PRESSURE



TEMPERATURE



ELECTRONICS