



LEVEL



FLOW



PRESSURE



TEMPERATURE



ELECTRONICS



Датчики уровня взрывозащищенные стандарта АTEX E – EAC GOST серии MULTIPPOINT – L-O

Архангельск (8182)63-90-72
Астрахань (8512)99-46-04
Барнаул (3852)73-04-60
Белгород (4722)40-23-64
Брянск (4832)59-03-52
Владивосток (423)249-28-31
Волгоград (844)278-03-48
Вологда (8172)26-41-59
Воронеж (473)204-51-73
Екатеринбург (343)384-55-89
Иваново (4932)77-34-06

Ижевск (3412)26-03-58
Иркутск (395)279-98-46
Казань (843)206-01-48
Калининград (4012)72-03-81
Калуга (4842)92-23-67
Кемерово (3842)65-04-62
Киров (8332)68-02-04
Краснодар (861)203-40-90
Красноярск (391)204-63-61
Курск (4712)77-13-04
Липецк (4742)52-20-81

Киргизия (996)312-96-26-47

Магнитогорск (3519)55-03-13
Москва (495)268-04-70
Мурманск (8152)59-64-93
Набережные Челны (8552)20-53-41
Нижний Новгород (831)429-08-12
Новокузнецк (3843)20-46-81
Новосибирск (383)227-86-73
Омск (3812)21-46-40
Орел (4862)44-53-42
Оренбург (3532)37-68-04
Пенза (8412)22-31-16

Казахстан (7273)495-231

Пермь (342)205-81-47
Ростов-на-Дону (863)308-18-15
Рязань (4912)46-61-64
Самара (846)206-03-16
Санкт-Петербург (812)309-46-40
Саратов (845)249-38-78
Севастополь (8692)22-31-93
Симферополь (3652)67-13-56
Соленск (4812)29-41-54
Сочи (862)225-72-31
Ставрополь (8652)20-65-13

Таджикистан (992)427-82-92-69

Сургут (3462)77-98-35
Тверь (4822)63-31-35
Томск (3822)98-41-53
Тула (4872)74-02-29
Тюмень (3452)66-21-18
Ульяновск (8422)24-23-59
Уфа (347)229-48-12
Хабаровск (4212)92-98-04
Хельсинки (351)202-03-61
Череповец (8202)49-02-64
Ярославль (4852)69-52-93

Единый адрес для всех регионов: vck@nt-rt.ru || <https://valco.nt-rt.ru/>

APPROVED IN ACCORDANCE WITH THE EUROPEAN STANDARD 94/9/EC - ATEX



These instruments, explosion-proof certified **CESI 03 ATEX 272 Ext.2 II 1/2G Exd IIB IIC T5/T6 Ga/Gb**, are used to control the level of liquids or fuel in tanks, both underground and outdoors, installed in hazardous areas where flammable products are treated.

GENERAL CHARACTERISTICS

- **Brass – Spansil – Stainless steel rod**
- Up to 4 switch points.
- Maximum working pressure 20 bar.
- Standard working temperature up to 100°C.
- Executions up to 120°C on request.
- Operating ambient temperature -40/+40°C = T6, -40/+60°C = T5
- Minimum degree of protection IP66.
- Built-in temperature sensors, on request.
PT – PTC – NTC – Thermostat (Thermoprotector).

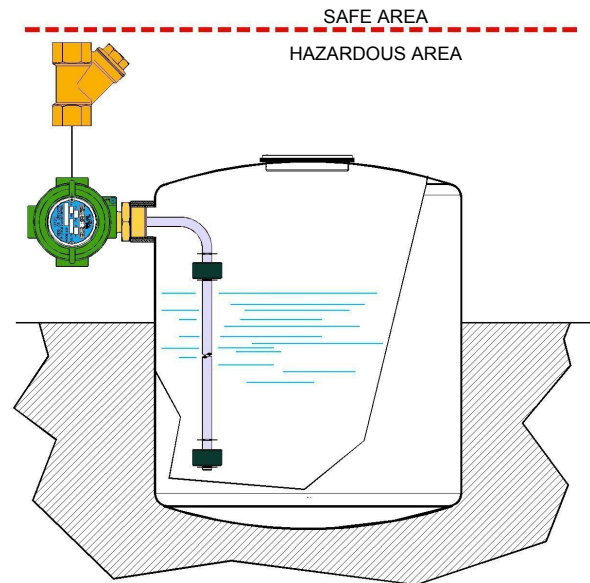

FLOATS

Tab.1



Material	Spansil – Butadiene - Acrylonitrile Copolymer											
Specific gravity	0,59	0,44	0,4	0,45	0,4	0,35	0,45					
Contact type	3	3	6D	3	6D	3	3	6D	4	6	4	6
Max N. contacts	1	1	1	3	4	4	4	4	4	4	4	4
Max. bar	10				20							
Max. °C - Class					L = 100°C							
On request					M = 120°C							

ELECTRICAL CONTACTS

Tab.2

TYPE		POWER		VOLTAGE		CURRENT	
		VA	W	AC	DC	AC	DC
SPST	3	70	50	300	350	0,5	0,7
SPST	4	80	80	250	250	1,3	1,3
SPDT	6	60	60	230	230	1	1
SPDT	6D	20	20	150	150	0,5	0,5

ELECTRICAL OUTPUT

Tab.3

E1	IP66 Housing Max. 18 terminals
-----------	-----------------------------------

Heatsink - see dimension (*)	Temperature class M
-------------------------------------	----------------------------

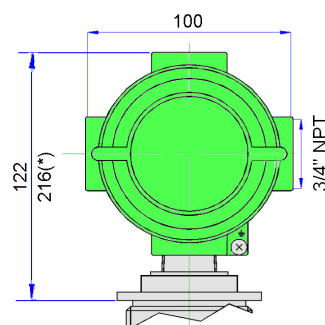

PROCESS CONNECTION Tab.4

Float type	Installation from outside – available thread and flanges							
	20 3/4"	25 1"	32 1 1/4"	40 1 1/2"	50 2"	FOHX Flange	DN50 Flange	DN65 Flange
B13	G-C-N	-	-	-	-	-	-	-
B22	G-C-N	G-C-N	-	-	-	•	-	-
B28	G-C-N	G-C-N	-	-	-	•	-	-
B15	-	G-C-N	-	-	-	-	-	-
B20	-	G	G-C-N	-	-	•	•	-
B45	-	G	G-C-N	G-C-N	-	•	•	-
B44	-	-	-	G	G-C-N	•	•	•

Male thread

G	C	N
Cylindrical UNI 228/1	Conical UNI 7/1	Conical NPT

Available materials

O	S
Brass	AISI-316 On request

DN = Available materials

C	S
Steel	AISI-316 On request

FLANGES Dimensions in mm.

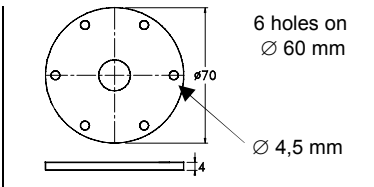

FOHX

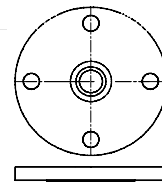

DN = UNI – DIN – ANSI flanges

WIRING Tab.5

I	Independent	Separately wired contacts	1	NO	Contacts status in no level conditions
C	Common	Common wired contacts	2	NC	
S	Custom	Contacts wired on request	3	SPDT	

SWITCH POINTS - minimum value in mm. Tab.6

Switch points L1+L4 are measured from the axis of fitting or flange connection. Tolerances ± 3 mm.

	Minimum distance in mm.							
	B13	B22	B28	B15	B20	B45	B44	
A min.	60	60	60	55	60	60	80	
A1 min.	60	60	60	55	60	75	80	
B	25	25	25	20	20	40	40	
C	-	-	-	35	40	75	75	
D max. ▶	18	22	24	25	24	24	36	
Contact type	3	3 6D	3 6D	3	3 6D	4 6	4 6	
Max. N. contacts	1	1	1	3	4	4	4	

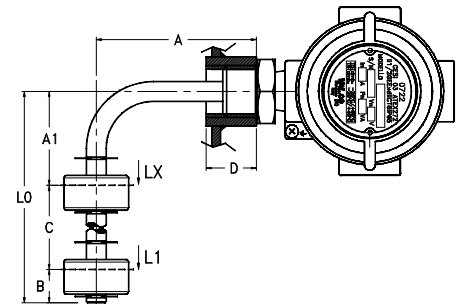

OPTION – Built-in temperature sensor

On request, it is possible to install a temperature sensor located at the bottom of the rod inside the instrument.

PT100 – PT1000	PTC	NTC	TRP (Thermoprotector)
EN 60751 – IEC 751	Resistance at 25°C $\leq 500 \Omega$	Resistance at 25°C 2-5-10-50-100 K Ω	70°C + 120°C - 10°C step
Class B – A (on request)	Temperature 60°C + 120°C	Precision $\pm 5\%$ / $\pm 3\%$ (on request)	Precision $\pm 5\%$ Differential 40°C

NOMENCLATURE

L2	B45	4	0350/0100	S	25	G	O	E1	L	I22	L1+L4	
•												Number of contacts L1+L4
	•											Tab.1 Float
		•										Tab.2 Electrical contact
			•									- Total length = L0 mm / Length A mm. (See drawing)
				•								- Stainless steel rod material
					•							Tab.4 Process connection dimension
						•						Tab.4 Process connection thread
							•					Tab.4 Process connection material
								•				Tab.3 Electrical output
									•			Tab.1 Temperature class
										•		Tab.5 Wiring and contact status
											•	Tab.6 Switch points (mm)

All level controls Exd certified must be connected by interposing the appropriate blocking joints according to the European Standard EN 50018.

По вопросам продажи и поддержки обращайтесь:

Архангельск (8182)63-90-72
Астрахань (8512)99-46-04
Барнаул (3852)73-04-60
Белгород (4722)40-23-64
Брянск (4832)59-03-52
Владивосток (423)249-28-31
Волгоград (844)278-03-48
Волгода (8172)26-41-59
Воронеж (473)204-51-73
Екатеринбург (343)384-55-89
Иваново (4932)77-34-06

Ижевск (3412)26-03-58
Иркутск (395)279-98-46
Казань (843)206-01-48
Калининград (4012)72-03-81
Калуга (4842)92-23-67
Кемерово (3842)65-04-62
Киров (8332)68-02-04
Краснодар (861)203-40-90
Красноярск (391)204-63-61
Курск (4712)77-13-04
Липецк (4742)52-20-81

Магнитогорск (3519)55-03-13
Москва (495)268-04-70
Мурманск (8152)59-64-93
Набережные Челны (8552)20-53-41
Нижний Новгород (831)429-08-12
Новокузнецк (3843)20-46-81
Новосибирск (383)227-86-73
Омск (3812)21-46-40
Орел (4862)44-53-42
Оренбург (3532)37-68-04
Пенза (8412)22-31-16

Пермь (342)205-81-47
Ростов-на-Дону (863)308-18-15
Рязань (4912)46-61-64
Самара (846)206-03-16
Санкт-Петербург (812)309-46-40
Саратов (845)249-38-78
Севастополь (8692)22-31-93
Симферополь (3652)67-13-56
Смоленск (4812)29-41-54
Сочи (862)225-72-31
Ставрополь (8652)20-65-13

Сургут (3462)77-98-35
Тверь (4822)63-31-35
Томск (3822)98-41-53
Тула (4872)74-02-29
Тюмень (3452)66-21-18
Ульяновск (8422)24-23-59
Уфа (347)229-48-12
Хабаровск (4212)92-98-04
Челябинск (351)202-03-61
Череповец (8202)49-02-64
Ярославль (4852)69-52-93

Киргизия (996)312-96-26-47

Казахстан (7273)495-231

Таджикистан (992)427-82-92-69

Единый адрес для всех регионов: vck@nt-rt.ru || <https://valco.nt-rt.ru/>



LEVEL



FLOW



PRESSURE



TEMPERATURE



ELECTRONICS