



LEVEL



FLOW



PRESSURE



TEMPERATURE



ELECTRONICS



Датчики потока серии FLOW – MR1K

Архангельск (8182)63-90-72
 Астрахань (8512)99-46-04
 Барнаул (3852)73-04-60
 Белгород (4722)40-23-64
 Брянск (4832)59-03-52
 Владивосток (423)249-28-31
 Волгоград (844)278-03-48
 Вологда (8172)26-41-59
 Воронеж (473)204-51-73
 Екатеринбург (343)384-55-89
 Иваново (4932)77-34-06

Ижевск (3412)26-03-58
 Иркутск (395)279-98-46
 Казань (843)206-01-48
 Калининград (4012)72-03-81
 Калуга (4842)92-23-67
 Кемерово (3842)65-04-62
 Киров (8332)68-02-04
 Краснодар (861)203-40-90
 Красноярск (391)204-63-61
 Курск (4712)77-13-04
 Липецк (4742)52-20-81

Киргизия (996)312-96-26-47

Магнитогорск (3519)55-03-13
 Москва (495)268-04-70
 Мурманск (8152)59-64-93
 Набережные Челны (8552)20-53-41
 Нижний Новгород (831)429-08-12
 Новокузнецк (3843)20-46-81
 Новосибирск (383)227-86-73
 Омск (3812)21-46-40
 Орел (4862)44-53-42
 Оренбург (3532)37-68-04
 Пенза (8412)22-31-16

Казахстан (7273)495-231

Пермь (342)205-81-47
 Ростов-на-Дону (863)308-18-15
 Рязань (4912)46-61-64
 Самара (846)206-03-16
 Санкт-Петербург (812)309-46-40
 Саратов (845)249-38-78
 Севастополь (8692)22-31-93
 Симферополь (3652)67-13-56
 Смоленск (4812)29-41-54
 Сочи (862)225-72-31
 Ставрополь (8652)20-65-13

Таджикистан (992)427-82-92-69

Сургут (3462)77-98-35
 Тверь (4822)63-31-35
 Томск (3822)98-41-53
 Тула (4872)74-02-29
 Тюмень (3452)66-21-18
 Ульяновск (8422)24-23-59
 Уфа (347)229-48-12
 Хабаровск (4212)92-98-04
 Челябинск (351)202-03-61
 Череповец (8202)49-02-64
 Ярославль (4852)69-52-93

Единый адрес для всех регионов: vck@nt-rt.ru || <https://valco.nt-rt.ru/>

GENERAL CHARACTERISTICS

This flow switch, as regards the detection of the flow rate through the system of floating piston, introduces a series of improvements that elevate the reliability.

The flow chamber and the sensing element have been redesigned to obtain a better stability to changes in viscosity and a greater insensitivity to possible impurities of the fluid.

The calibration system, with safety lock, allows accurate adjustment of the set value. The electrical connection is made via DIN 43650 and PG9

- Hermetic separation between the flow chamber and electric head
- No restrictions on mounting position
- High pressure and operating temperature
- Calibration adjustment

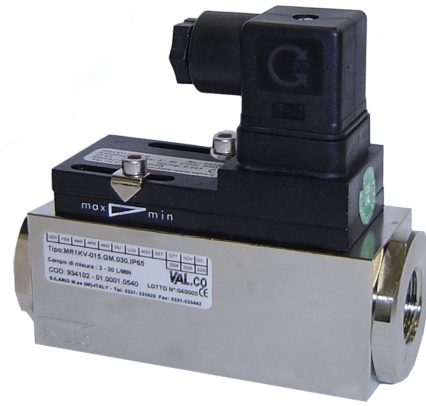

TECHNICAL DATA

Tab.1

DN	Type	P max Bar	T max °C	Adjustable ranges l/min H ₂ O			Q max l/min	ΔP Q max Bar	
008	1/4"	MR1KV-008	200	120	0.4 – 4			10	0.5
010	3/8"	MR1KV-010	200	120	0.4 – 4	1 – 10		20	0.5
015	1/2"	MR1KV-015	200	120	1 – 10	2 – 20	3 – 30	40	0.5
020	3/4"	MR1KV-020	200	120	3 – 30		4 – 40	60	0.5
025	1"	MR1KV-025	200	120	4 – 40		6 – 60	80	0.5

Code Adjustable range	
0,4 – 4	004
1 – 10	010
2 – 20	020
3 – 30	030
4 – 40	040
6 – 60	060

Setting ranges for horizontal and decreasing flow

DN	Thread	Gas - parallel UNI 228/1
Accuracy	± 5% F.S.	
Hysteresis	10% - minimum 0,5 l/min	

MATERIALS

Tab.2

Description	Code GM	Code GK
Body	Nickel plated brass	Stainless steel 1.4571
Piston	Brass	Stainless steel 1.4404
Spring	Stainless steel 1.4310	Stainless steel 1.4310
Magnet	Ferrite	Ferrite PTFE coated
Switch head	Polycarbonate	Polycarbonate

ELECTRICAL DATA

Tab.3

Description	Characteristics					
Contact	REED	SPDT	250VCA	1,5A	50VA	
Electrical output	Plug		DIN 43650A			
Protection	IP65					
Option						
Diode	LED	Red color integrated in the plug DIN cap				
Voltage	Vac/cc	230	110	48	24	12 To be specified

DIMENSIONS

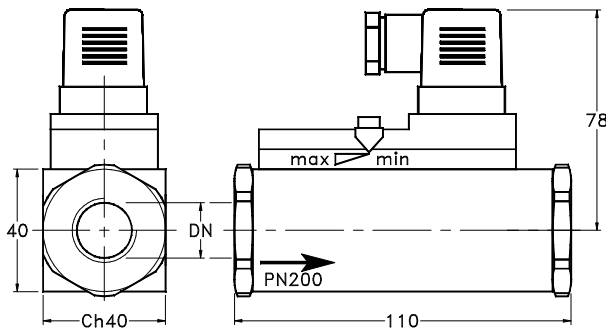

WIRING

Tab.4

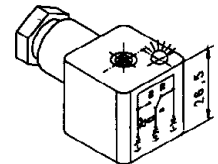
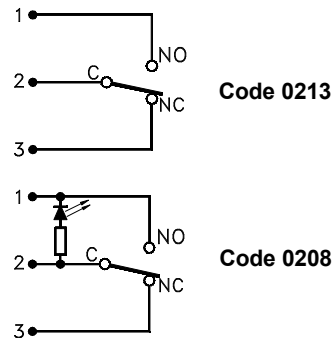

When using DC, comply with the polarity indicated

NOMENCLATURE

MR1KV	025	GM	060	IP65	0213
•					
	•				
		•			
			•		
				•	
					•

	Nome - TYPe
Tab.1	Process connection dimensions
Tab.2	Material
Tab.1	Setting range
Tab.3	Degree of protection
Tab.4	Wiring

По вопросам продажи и поддержки обращайтесь:

Архангельск (8182)63-90-72
Астрахань (8512)99-46-04
Барнаул (3852)73-04-60
Белгород (4722)40-23-64
Брянск (4832)59-03-52
Владивосток (423)249-28-31
Волгоград (844)278-03-48
Вологда (8172)26-41-59
Воронеж (473)204-51-73
Екатеринбург (343)384-55-89
Иваново (4932)77-34-06

Ижевск (3412)26-03-58
Иркутск (395)279-98-46
Казань (843)206-01-48
Калининград (4012)72-03-81
Калуга (4842)92-23-67
Кемерово (3842)65-04-62
Киров (8332)68-02-04
Краснодар (861)203-40-90
Красноярск (391)204-63-61
Курск (4712)77-13-04
Липецк (4742)52-20-81

Киргизия (996)312-96-26-47

Магнитогорск (3519)55-03-13
Москва (495)268-04-70
Мурманск (8152)59-64-93
Набережные Челны (8552)20-53-41
Нижний Новгород (831)429-08-12
Новокузнецк (3843)20-46-81
Новосибирск (383)227-86-73
Омск (3812)21-46-40
Орел (4862)44-53-42
Оренбург (3532)37-68-04
Пенза (8412)22-31-16

Казахстан (7273)495-231

Пермь (342)205-81-47
Ростов-на-Дону (863)308-18-15
Рязань (4912)46-61-64
Самара (846)206-03-16
Санкт-Петербург (812)309-46-40
Саратов (845)249-38-78
Севастополь (8692)22-31-93
Симферополь (3652)67-13-56
Смоленск (4812)29-41-54
Сочи (862)225-72-31
Ставрополь (8652)20-65-13

Таджикистан (992)427-82-92-69

Сургут (3462)77-98-35
Тверь (4822)63-31-35
Томск (3822)98-41-53
Тула (4872)74-02-29
Тюмень (3452)66-21-18
Ульяновск (8422)24-23-59
Уфа (347)229-48-12
Хабаровск (4212)92-98-04
Челябинск (351)202-03-61
Череповец (8202)49-02-64
Ярославль (4852)69-52-93

Единый адрес для всех регионов: vck@nt-rt.ru || <https://valco.nt-rt.ru/>



LEVEL



FLOW



PRESSURE



TEMPERATURE



ELECTRONICS