



LEVEL



FLOW



PRESSURE



TEMPERATURE



ELECTRONICS



Датчики потока серии FLOW – VO.V2

Архангельск (8182)63-90-72
 Астрахань (8512)99-46-04
 Барнаул (3852)73-04-60
 Белгород (4722)40-23-64
 Брянск (4832)59-03-52
 Владивосток (423)249-28-31
 Волгоград (844)278-03-48
 Вологда (8172)26-41-59
 Воронеж (473)204-51-73
 Екатеринбург (343)384-55-89
 Иваново (4932)77-34-06

Ижевск (3412)26-03-58
 Иркутск (395)279-98-46
 Казань (843)206-01-48
 Калининград (4012)72-03-81
 Калуга (4842)92-23-67
 Кемерово (3842)65-04-62
 Киров (8332)68-02-04
 Краснодар (861)203-40-90
 Красноярск (391)204-63-61
 Курск (4712)77-13-04
 Липецк (4742)52-20-81

Киргизия (996)312-96-26-47

Магнитогорск (3519)55-03-13
 Москва (495)268-04-70
 Мурманск (8152)59-64-93
 Набережные Челны (8552)20-53-41
 Нижний Новгород (831)429-08-12
 Новокузнецк (3843)20-46-81
 Новосибирск (383)227-86-73
 Омск (3812)21-46-40
 Орел (4862)44-53-42
 Оренбург (3532)37-68-04
 Пенза (8412)22-31-16

Казахстан (7273)495-231

Пермь (342)205-81-47
 Ростов-на-Дону (863)308-18-15
 Рязань (4912)46-61-64
 Самара (846)206-03-16
 Санкт-Петербург (812)309-46-40
 Саратов (845)249-38-78
 Севастополь (8692)22-31-93
 Симферополь (3652)67-13-56
 Смоленск (4812)29-41-54
 Сочи (862)225-72-31
 Ставрополь (8652)20-65-13

Таджикистан (992)427-82-92-69

Сургут (3462)77-98-35
 Тверь (4822)63-31-35
 Томск (3822)98-41-53
 Тула (4872)74-02-29
 Тюмень (3452)66-21-18
 Ульяновск (8422)24-23-59
 Уфа (347)229-48-12
 Хабаровск (4212)92-98-04
 Челябинск (351)202-03-61
 Череповец (8202)49-02-64
 Ярославль (4852)69-52-93

Единый адрес для всех регионов: vck@nt-rt.ru || <https://valco.nt-rt.ru/>

GENERAL CHARACTERISTICS



Piston flow switch float measuring principle. The flow working range depends from the differential pressure generated in the flow chamber. The adjustment is very simple and the setting mechanism has a safe locking system.

Electrical connection by DIN 43650-A plug.

- Flow visual indication
- High switch accuracy
- Hermetic separation of mechanical and electrical components
- Free installation position



TECHNICAL DATA

Tab.1

DN	Ø	Type	P max Bar	T max °C		Adjustable range l/min H2O	Code Range
				S	H		
015	1/2"	VO.V2-015.GM	16	100	160	0,2 - 0,5	0005
						0,3 - 1	001
						0,7 - 2	002
						1,6 - 4	004
						3,0 - 8	008
						4,5 - 12	012
						6,0 - 15	015
						8,0 - 20	020
						9,5 - 24	024
						12 - 28	028

Adjustable ranges are indicated for horizontally decreasing flow

DN	Thread	UNI 228/1
Accuracy	± 10% F.S.	
Hysteresis	15% - minimum 0,5	
Pressure drop	0,02 to 0,3 bar	

MATERIALS

Tab.2

	GM	GK
Housing (*)	Anodized aluminium	Anodized aluminium
Sight glass	Duran® 50	Duran® 50
Piston	Brass	St. steel 1.4571
Spring	St. steel 1.4571	St. steel 1.4571

(*) non wetted part

ELECTRICAL DATA

Tab.3

Description	Characteristics				
Contact	Reed	N.A.	250V	3,0A	100VA
			SPDT(*)	250V	1,5A
Electrical entry	Plug		DIN 43650-A	IP65	
			M12x1	IP67	

(*) minimum load 3V

DRAWING

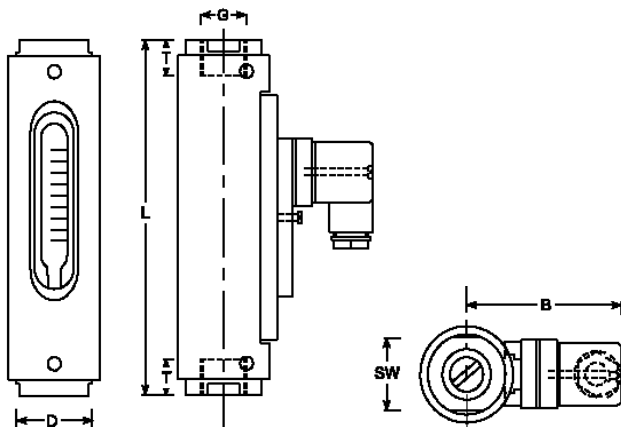

DIMENSIONS - mm

DN	SW	D	B	T	L	Kg
015	27	32	53	14	114	0,30

WIRING

Tab.4

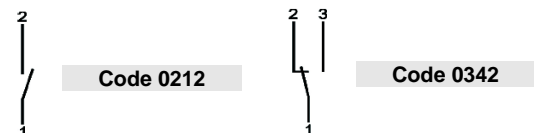

NOMENCLATURE

VO.V2	015	GM	002	IP65-S	0212
•					
	•				
		•			
			•		
				•	
					•

	Type
Tab.1	Size and connections thread
Tab.2	Material
Tab.1	Adjustable range
Tab.1-3	Protection class – Temperature class
Tab.4	Wiring – Contact type

По вопросам продажи и поддержки обращайтесь:

Архангельск (8182)63-90-72
Астрахань (8512)99-46-04
Барнаул (3852)73-04-60
Белгород (4722)40-23-64
Брянск (4832)59-03-52
Владивосток (423)249-28-31
Волгоград (844)278-03-48
Вологда (8172)26-41-59
Воронеж (473)204-51-73
Екатеринбург (343)384-55-89
Иваново (4932)77-34-06

Ижевск (3412)26-03-58
Иркутск (395)279-98-46
Казань (843)206-01-48
Калининград (4012)72-03-81
Калуга (4842)92-23-67
Кемерово (3842)65-04-62
Киров (8332)68-02-04
Краснодар (861)203-40-90
Красноярск (391)204-63-61
Курск (4712)77-13-04
Липецк (4742)52-20-81

Киргизия (996)312-96-26-47

Магнитогорск (3519)55-03-13
Москва (495)268-04-70
Мурманск (8152)59-64-93
Набережные Челны (8552)20-53-41
Нижний Новгород (831)429-08-12
Новокузнецк (3843)20-46-81
Новосибирск (383)227-86-73
Омск (3812)21-46-40
Орел (4862)44-53-42
Оренбург (3532)37-68-04
Пенза (8412)22-31-16

Казахстан (7273)495-231

Пермь (342)205-81-47
Ростов-на-Дону (863)308-18-15
Рязань (4912)46-61-64
Самара (846)206-03-16
Санкт-Петербург (812)309-46-40
Саратов (845)249-38-78
Севастополь (8692)22-31-93
Симферополь (3652)67-13-56
Смоленск (4812)29-41-54
Сочи (862)225-72-31
Ставрополь (8652)20-65-13

Таджикистан (992)427-82-92-69

Сургут (3462)77-98-35
Тверь (4822)63-31-35
Томск (3822)98-41-53
Тула (4872)74-02-29
Тюмень (3452)66-21-18
Ульяновск (8422)24-23-59
Уфа (347)229-48-12
Хабаровск (4212)92-98-04
Челябинск (351)202-03-61
Череповец (8202)49-02-64
Ярославль (4852)69-52-93

Единый адрес для всех регионов: vck@nt-rt.ru || <https://valco.nt-rt.ru/>



LEVEL



FLOW



PRESSURE



TEMPERATURE



ELECTRONICS