



LEVEL



FLOW



PRESSURE



TEMPERATURE



ELECTRONICS



# Датчики потока серии FLOW – VO.VL2

Архангельск (8182)63-90-72  
 Астрахань (8512)99-46-04  
 Барнаул (3852)73-04-60  
 Белгород (4722)40-23-64  
 Брянск (4832)59-03-52  
 Владивосток (423)249-28-31  
 Волгоград (844)278-03-48  
 Вологда (8172)26-41-59  
 Воронеж (473)204-51-73  
 Екатеринбург (343)384-55-89  
 Иваново (4932)77-34-06

Ижевск (3412)26-03-58  
 Иркутск (395)279-98-46  
 Казань (843)206-01-48  
 Калининград (4012)72-03-81  
 Калуга (4842)92-23-67  
 Кемерово (3842)65-04-62  
 Киров (8332)68-02-04  
 Краснодар (861)203-40-90  
 Красноярск (391)204-63-61  
 Курск (4712)77-13-04  
 Липецк (4742)52-20-81

Киргизия (996)312-96-26-47

Магнитогорск (3519)55-03-13  
 Москва (495)268-04-70  
 Мурманск (8152)59-64-93  
 Набережные Челны (8552)20-53-41  
 Нижний Новгород (831)429-08-12  
 Новокузнецк (3843)20-46-81  
 Новосибирск (383)227-86-73  
 Омск (3812)21-46-40  
 Орел (4862)44-53-42  
 Оренбург (3532)37-68-04  
 Пенза (8412)22-31-16

Казахстан (7273)495-231

Пермь (342)205-81-47  
 Ростов-на-Дону (863)308-18-15  
 Рязань (4912)46-61-64  
 Самара (846)206-03-16  
 Санкт-Петербург (812)309-46-40  
 Саратов (845)249-38-78  
 Севастополь (8692)22-31-93  
 Симферополь (3652)67-13-56  
 Смоленск (4812)29-41-54  
 Сочи (862)225-72-31  
 Ставрополь (8652)20-65-13

Таджикистан (992)427-82-92-69

Сургут (3462)77-98-35  
 Тверь (4822)63-31-35  
 Томск (3822)98-41-53  
 Тула (4872)74-02-29  
 Тюмень (3452)66-21-18  
 Ульяновск (8422)24-23-59  
 Уфа (347)229-48-12  
 Хабаровск (4212)92-98-04  
 Челябинск (351)202-03-61  
 Череповец (8202)49-02-64  
 Ярославль (4852)69-52-93

Единый адрес для всех регионов: [vck@nt-rt.ru](mailto:vck@nt-rt.ru) || <https://valco.nt-rt.ru/>

## GENERAL CHARACTERISTICS



Piston flow switch float measuring principle. The flow working range depends from the differential pressure generated in the flow chamber. The adjustment is very simple and the setting mechanism has a safe locking system.

Electrical connection by DIN 43650-A plug.

- Air and gas application
- Flow visual indication
- High switch accuracy
- Hermetic separation of mechanical and electrical components
- Free installation position



## TECHNICAL DATA Tab.1

DN	Ø	Type	P max Bar	T max °C		Adjustable range NI/min – Air (*)	Code Range
				L	H		
015	1/2"	VO.VL2-015.GM	16	100	160	3 - 12	L012
						7 - 30	L030
						12 - 40	L040
						20 - 80	L080
						28 - 125	L125
						50 - 200	L200
						100 - 420	L420
120 - 480	L480						

DN	Thread	UNI 228/1
----	--------	-----------

Accuracy	± 10% F.S.
Hysteresis	15% - minimum 0,5
Pressure drop	0,02 to 0,3 bar

(\*) Air at 1 bar absolute and 20°C

Adjustable ranges are indicated for horizontally decreasing flow

## MATERIALS Tab.2

	GM	GK
Housing (*)	Anodized aluminium	Anodized aluminium
Sight glass	Duran® 50	Duran® 50
Piston	Brass	St. steel 1.4571
Spring	St. steel 1.4571	St. steel 1.4571

(\*) non wetted part

## ELECTRICAL DATA Tab.3

Description	Characteristics				
	N.A.	230V	3,0A	60VA	S1
Contact - reed	SPDT(*)	250V	1,5A	50VA	
	N.A.	125V	3,0A	60VA	
Electrical entry	Plug	DIN 43650-C		S1	IP65
		M12x1 (**)		S3	

(\*) minimum load 3V

(\*\*) T max -20 / +85°C only = X code

## DRAWING

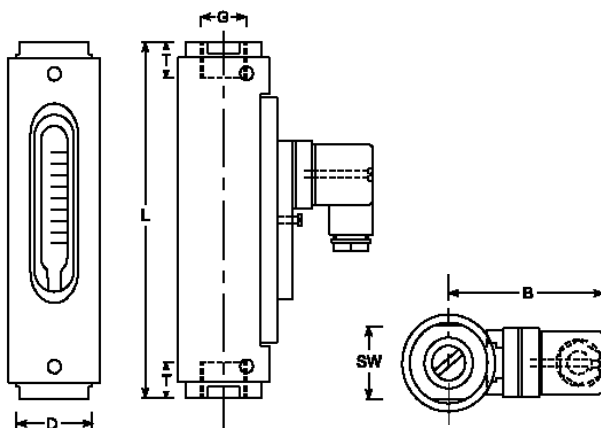

## DIMENSIONS - mm

DN	SW	D	B	T	L	Kg
015	27	32	53	14	114	0,30

## WIRING Tab.4

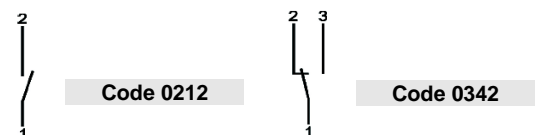

## NOMENCLATURE

VO.VL2	015	GM	L040	S1	IP65-L	0212
•						
	•					
		•				
			•			
				•		
					•	
						•

	Type
Tab.1	Size and connections thread
Tab.2	Material
Tab.1	Adjustable range
Tab.3	Electrical connection and switch electrical data
Tab.1-3	Protection class – Temperature class
Tab.4	Wiring – Contact type

## По вопросам продажи и поддержки обращайтесь:

**Архангельск** (8182)63-90-72  
**Астрахань** (8512)99-46-04  
**Барнаул** (3852)73-04-60  
**Белгород** (4722)40-23-64  
**Брянск** (4832)59-03-52  
**Владивосток** (423)249-28-31  
**Волгоград** (844)278-03-48  
**Вологда** (8172)26-41-59  
**Воронеж** (473)204-51-73  
**Екатеринбург** (343)384-55-89  
**Иваново** (4932)77-34-06

**Ижевск** (3412)26-03-58  
**Иркутск** (395)279-98-46  
**Казань** (843)206-01-48  
**Калининград** (4012)72-03-81  
**Калуга** (4842)92-23-67  
**Кемерово** (3842)65-04-62  
**Киров** (8332)68-02-04  
**Краснодар** (861)203-40-90  
**Красноярск** (391)204-63-61  
**Курск** (4712)77-13-04  
**Липецк** (4742)52-20-81

**Киргизия** (996)312-96-26-47

**Магнитогорск** (3519)55-03-13  
**Москва** (495)268-04-70  
**Мурманск** (8152)59-64-93  
**Набережные Челны** (8552)20-53-41  
**Нижний Новгород** (831)429-08-12  
**Новокузнецк** (3843)20-46-81  
**Новосибирск** (383)227-86-73  
**Омск** (3812)21-46-40  
**Орел** (4862)44-53-42  
**Оренбург** (3532)37-68-04  
**Пенза** (8412)22-31-16

**Казахстан** (7273)495-231

**Пермь** (342)205-81-47  
**Ростов-на-Дону** (863)308-18-15  
**Рязань** (4912)46-61-64  
**Самара** (846)206-03-16  
**Санкт-Петербург** (812)309-46-40  
**Саратов** (845)249-38-78  
**Севастополь** (8692)22-31-93  
**Симферополь** (3652)67-13-56  
**Смоленск** (4812)29-41-54  
**Сочи** (862)225-72-31  
**Ставрополь** (8652)20-65-13

**Таджикистан** (992)427-82-92-69

**Сургут** (3462)77-98-35  
**Тверь** (4822)63-31-35  
**Томск** (3822)98-41-53  
**Тула** (4872)74-02-29  
**Тюмень** (3452)66-21-18  
**Ульяновск** (8422)24-23-59  
**Уфа** (347)229-48-12  
**Хабаровск** (4212)92-98-04  
**Челябинск** (351)202-03-61  
**Череповец** (8202)49-02-64  
**Ярославль** (4852)69-52-93

Единый адрес для всех регионов: [vck@nt-rt.ru](mailto:vck@nt-rt.ru) || <https://valco.nt-rt.ru/>



LEVEL



FLOW



PRESSURE



TEMPERATURE



ELECTRONICS