



LEVEL



FLOW



PRESSURE



TEMPERATURE



ELECTRONICS



Усилитель сигнала ELECTRA – VNR-23M

Архангельск (8182)63-90-72
Астрахань (8512)99-46-04
Барнаул (3852)73-04-60
Белгород (4722)40-23-64
Брянск (4832)59-03-52
Владивосток (423)249-28-31
Волгоград (844)278-03-48
Вологда (8172)26-41-59
Воронеж (473)204-51-73
Екатеринбург (343)384-55-89
Иваново (4932)77-34-06

Ижевск (3412)26-03-58
Иркутск (395)279-98-46
Казань (843)206-01-48
Калининград (4012)72-03-81
Калуга (4842)92-23-67
Кемерово (3842)65-04-62
Киров (8332)68-02-04
Краснодар (861)203-40-90
Красноярск (391)204-63-61
Курск (4712)77-13-04
Липецк (4742)52-20-81

Киргизия (996)312-96-26-47

Магнитогорск (3519)55-03-13
Москва (495)268-04-70
Мурманск (8152)59-64-93
Набережные Челны (8552)20-53-41
Нижний Новгород (831)429-08-12
Новокузнецк (3843)20-46-81
Новосибирск (383)227-86-73
Омск (3812)21-46-40
Орел (4862)44-53-42
Оренбург (3532)37-68-04
Пенза (8412)22-31-16

Казахстан (7273)495-231

Пермь (342)205-81-47
Ростов-на-Дону (863)308-18-15
Рязань (4912)46-61-64
Самара (846)206-03-16
Санкт-Петербург (812)309-46-40
Саратов (845)249-38-78
Севастополь (8692)22-31-93
Симферополь (3652)67-13-56
Смоленск (4812)29-41-54
Сочи (862)225-72-31
Ставрополь (8652)20-65-13

Таджикистан (992)427-82-92-69

Сургут (3462)77-98-35
Тверь (4822)63-31-35
Томск (3822)98-41-53
Тула (4872)74-02-29
Тюмень (3452)66-21-18
Ульяновск (8422)24-23-59
Уфа (347)229-48-12
Хабаровск (4212)92-98-04
Челябинск (351)202-03-61
Череповец (8202)49-02-64
Ярославль (4852)69-52-93

Единый адрес для всех регионов: vck@nt-rt.ru || <https://valco.nt-rt.ru/>



GENERAL CHARACTERISTICS

This control unit with double measuring channels was designed as **low cost interface for conductive level probes** and is used to control liquids that have a minimum electrical conductivity of 8 μS .

The system measures the conductivity of the liquid to be controlled and works with low potential and with alternating currents, in order to avoid the incrustation of the electrodes and / or perforation of the tank normally caused by the use of direct currents, which cause a galvanic action on the materials. The contact of the electrode with the liquid determines the actuation of a relay inside the control unit. The presence of two measurement channels simultaneously allows to realize systems of control, metering, and safety.

- Adjustable sensitivity and delay
- Microprocessor technology
- 2 measuring channels
- DIN rail mounting

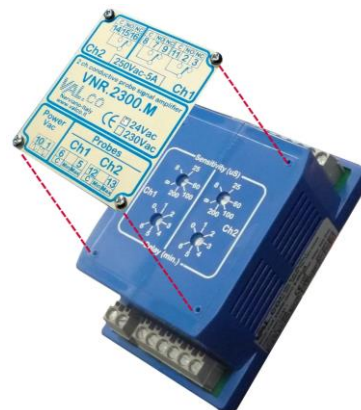

TECHNICAL DATA

Power supply	24 Vac 50/60 Hz	230 Vac On request
Power consumption	10 VA	
Input signal	From conductive probes	
Power supply to probe	15 Vac	
N. 2 channels output relay	Ch1 N. 2 SPDT Ch2 N. 1 SPDT	250Vac - 5A
Sensitivity	8 ÷ 250 μS	Factory setting 60 μS
Operation delay	0 ÷ 6 min.	Factory setting 1 min.
Adjustments	Trimmers under front plate	
Operating temperature	-20° ÷ +50° C	
Housing	ABS IP40	60 x 100 x 45 mm.
Mounting	DIN rail	
Electrical connection	17 poles terminal board	

DIMENSIONS mm.

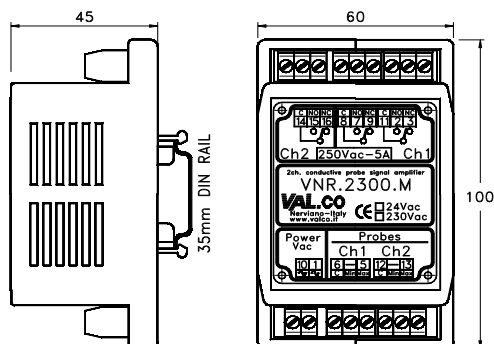

CONTROL AND ADJUSTMENT

Control:

- Disconnect the electrodes leads from the terminal board (Ch1 - terminals 5 and 6) (Ch2 - terminals 12 and 13).
- Short circuit terminals 5 and 6 of the terminal board, in these conditions, the Ch1 relays must switch on.
- Short circuit terminals 12 and 13 of the terminal board, in these conditions, the Ch2 relays must switch on.

Sensitivity and delay adjustment:

- The unit is supplied with a factory setting of 60 μS .
- Submerge the electrodes in the liquid under control, turn the trimmer (Sensitivity) under the front plate to obtain the switching of the relays.
- The operation delay can be adjusted with the trimmer (Delay) also located under the front plate.

NOMENCLATURE

VNR.2300M	2CH	8 – 250 μS	24 VCA
•			
	•		
		•	
			•

TERMINAL

FUNCTION

10	1	Power supply 24 Vac 50/60 Hz
6	12	Tank ground / ground electrode
-	CH1 -	Minimum level electrode
5	13	CH2 Maximum level electrode
2	NO	Ch1 N. 2 SPDT
3	NC	
11	COM	
7	NO	Ch1 Simultaneous action
9	NC	
8	COM	
15	NO	Ch2 N. 1 SPDT Ch2
16	NC	
14	COM	

TYPICAL WIRING

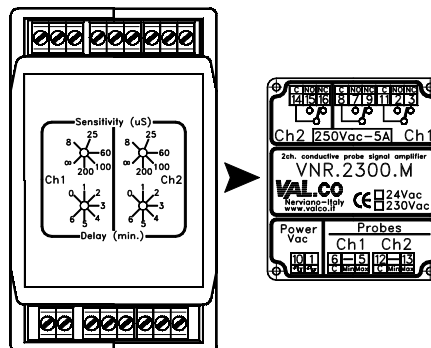
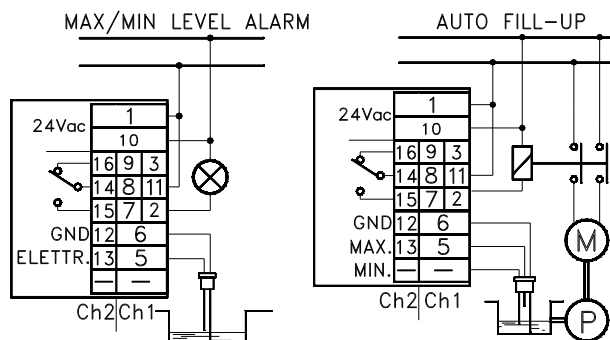

				Type
				Tab. 1 Number of channels
				Tab. 1 Sensitivity
				Tab. 1 Power supply

По вопросам продажи и поддержки обращайтесь:

Архангельск (8182)63-90-72
Астрахань (8512)99-46-04
Барнаул (3852)73-04-60
Белгород (4722)40-23-64
Брянск (4832)59-03-52
Владивосток (423)249-28-31
Волгоград (844)278-03-48
Волгода (8172)26-41-59
Воронеж (473)204-51-73
Екатеринбург (343)384-55-89
Иваново (4932)77-34-06

Ижевск (3412)26-03-58
Иркутск (395)279-98-46
Казань (843)206-01-48
Калининград (4012)72-03-81
Калуга (4842)92-23-67
Кемерово (3842)65-04-62
Киров (8332)68-02-04
Краснодар (861)203-40-90
Красноярск (391)204-63-61
Курск (4712)77-13-04
Липецк (4742)52-20-81

Киргизия (996)312-96-26-47

Магнитогорск (3519)55-03-13
Москва (495)268-04-70
Мурманск (8152)59-64-93
Набережные Челны (8552)20-53-41
Нижний Новгород (831)429-08-12
Новокузнецк (3843)20-46-81
Новосибирск (383)227-86-73
Омск (3812)21-46-40
Орел (4862)44-53-42
Оренбург (3532)37-68-04
Пенза (8412)22-31-16

Казахстан (7273)495-231

Пермь (342)205-81-47
Ростов-на-Дону (863)308-18-15
Рязань (4912)46-61-64
Самара (846)206-03-16
Санкт-Петербург (812)309-46-40
Саратов (845)249-38-78
Севастополь (8692)22-31-93
Симферополь (3652)67-13-56
Смоленск (4812)29-41-54
Сочи (862)225-72-31
Ставрополь (8652)20-65-13

Таджикистан (992)427-82-92-69

Сургут (3462)77-98-35
Тверь (4822)63-31-35
Томск (3822)98-41-53
Тула (4872)74-02-29
Тюмень (3452)66-21-18
Ульяновск (8422)24-23-59
Уфа (347)229-48-12
Хабаровск (4212)92-98-04
Челябинск (351)202-03-61
Череповец (8202)49-02-64
Ярославль (4852)69-52-93

Единый адрес для всех регионов: vck@nt-rt.ru || <https://valco.nt-rt.ru/>



LEVEL



FLOW



PRESSURE



TEMPERATURE



ELECTRONICS